

NF-50AX

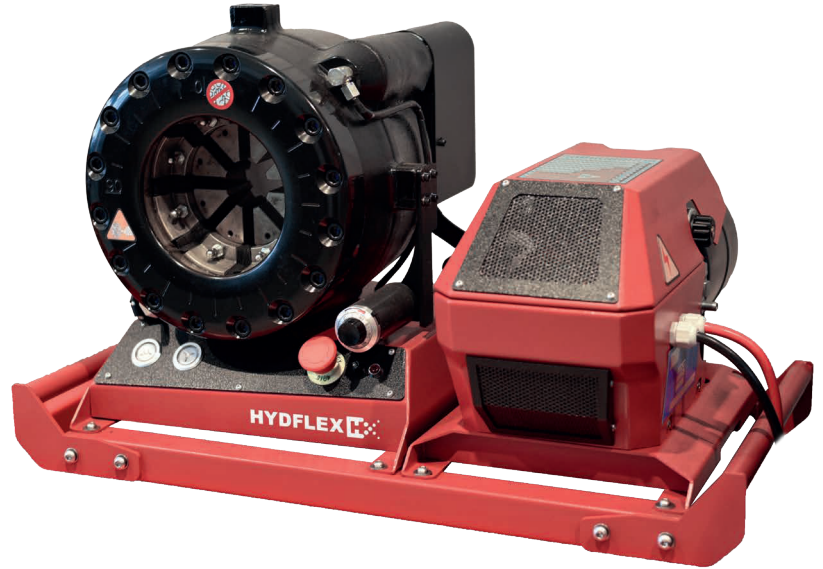

TECHNICAL SPECIFICATIONS

MODEL	NF-50AX																		
DIMENSIONS	600 x 480 x 520 mm																		
WEIGHT	178 kg																		
MAX CRIMPING FORCE	200 ton																		
MAX OPENING WITH DIES	Ø + 33 mm																		
MAX OPENING WITHOUT DIES	132 mm																		
MASTER DIE SIZE D/L	99/80 mm																		
MAX INSIDE DIAMETERS OF CRIMPED HOSES	1 braided	to 2"																	
	2 braided	to 2"																	
	4 braided SP	to 1 1/2"																	
	4 braided SH	to 1 1/4"																	
MIN. CRIMPING DIA	6 mm																		
MAX. CRIMPING DIA	87 mm																		
MOTOR POWER	12/24V 1.6/2.25																		
DIE DIMENSIONS	Die Ø	mm	06	08	10	12	14	16	19	22	26	30	34	39	45	51	57	63	69
	Length	mm	55						70			75		90		100			
74 & 78 size die sets sold separately																			
ACCESSORIES	Die panel for 15 sets																		
	Quick change tool																		
	Foot pedal																		
OPERATING MODE	Manual / Automatic																		

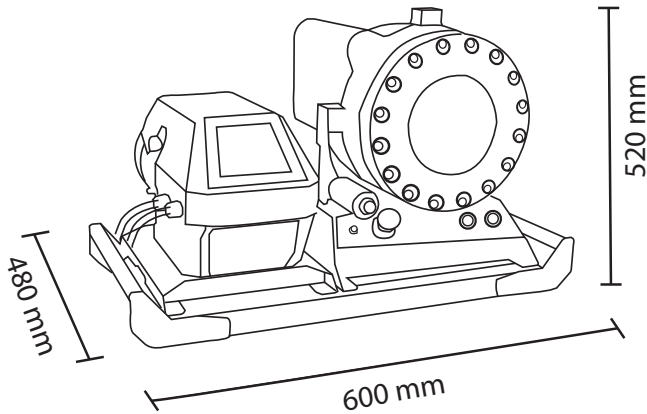

17 DIE SETS



PRECISE CALIBRATOR



OPERATING MODE
MANUAL/AUTOMATIC



DIE PANEL



MOTOR POWER



SAFETY SWITCH